

# Incremental Hollow Shaft Encoder

## RI 58-D, RI 58TD

Item No. 2 531 069, Edition: 3 160604 Ste1

Page 1/2

### Introduction

These installation instructions are provided for the connection and starting procedure of your shaft encoder. The shaft encoder is available in two versions: Standard version (RI 58-D) or High Temperature version (RI 58TD) and each in the mounting versions:

- F\* = Blind shaft with front clamping ring
- E\* = Blind shaft with screw connection
- D\* = through shaft with front clamping ring
- H\* = through shaft with rear clamping ring

\* F, E, D, H = code for mounting versions (see Identification code)

### Safety and Operating Instructions

- The incremental shaft encoders of the type RI 58-D / RI 58TD model series are quality products manufactured in accordance with established electrical engineering standards. The units have been delivered from the factory in perfect conformance to safety regulations. To maintain this condition and to ensure trouble-free operation, please observe the technical specifications of this document.
- Installation and mounting may only be performed by an electrotechnical expert!
- The units may only be operated within the limits specified by the technical data.
- Maximum operating voltages must not be exceeded!  
 The units are designed complying with VDE 0160, protection class III. To prevent dangerous structure-borne currents, the equipment has to be run on safety extra-low voltage (SELV) and must be in an area of equipotential bonding.
- Application: Industrial processes and control systems.  
 Overvoltage at the connecting terminals must be limited to the values within overvoltage category II.
- The high-quality EMC-specifications are only valid together with standard-type cables and plugs. When using screened cables, the screen must broadly be connected with ground on both ends. Likewise, the voltage-supply cables should entirely be screened. If this is not possible you will have to take appropriate filtering measures.
- Installation environment and wiring are influential on the encoder's EMC: Thus the installer must secure EMC of the whole facility (device).
- Transient peaks on the power supply leads are to be limited by the pre-connected power unit to a maximum of 1000 V.
- In electrostatically threatened areas please take care for neat ESD-protection of plug and connecting cable during installation work.
- For use in class II circuits only

### Connection diagram

Colour (TPE)	Colour (PVC)	Output RS 422 (T)	Output RS 422 (R)	Push-pull (K, D)	Push-pull complementary (I)
brown	white	Channel A	Channel A	Channel A	Channel A
green	white/brown	Channel $\bar{A}$	Channel $\bar{A}$		Channel $\bar{A}$
grey	green	Channel B	Channel B	Channel B	Channel B
pink	green/brown	Channel $\bar{B}$	Channel $\bar{B}$		Channel $\bar{B}$
red	yellow	Channel N	Channel N	Channel N	Channel N
black	yellow/brown	Channel $\bar{N}$	Channel $\bar{N}$		Channel $\bar{N}$
violet (white) <sup>2)</sup>	yellow/black	Sense GND	Alarm	Alarm	Alarm
blue	yellow/red	Sense V <sub>CC</sub>	Sense V <sub>CC</sub>		Sense V <sub>CC</sub>
brown/green red		5VDC	5/10...30VDC	5/10...30VDC	10...30VDC
white/green black		GND	GND	GND	GND
Screen <sup>1)</sup>	Screen <sup>1)</sup>	Screen <sup>1)</sup>	Screen <sup>1)</sup>	Screen <sup>1)</sup>	Screen <sup>1)</sup>

<sup>1)</sup> connected to encoder housing  
<sup>2)</sup> white for Sense (T)

### Identification code (see identification plate)

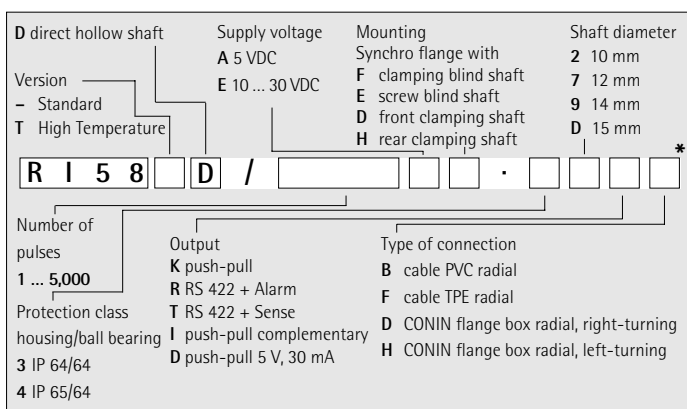

\* Special types are additionally marked by an ordering code -S. In this case customer specifications are to be applied. If you don't know these please call us for the specifications, indicating the encoder ordering code.

### Mechanical Data

Mounting	synchro flange with clamped shaft or blind shaft
Hollow shaft diameter	10/12/14/15 mm; required dim. of mounting shaft: $\varnothing$ 10 mm, tolerance g8 (-0.005 ... -0.027 mm) $\varnothing$ 12/14/15 mm, tolerance g8 (-0.006 ... -0.033 mm)
Speed	E, F: max. 6000 RPM; D, H: max. 4000 RPM
Torque	E, F: $\leq$ 1 Ncm (IP 64); D, H: $\leq$ 2 Ncm (IP 64)
Moment of inertia	F: approx. 35 gcm <sup>2</sup> ; E: approx. 20 gcm <sup>2</sup> ; D, H: 60 gcm <sup>2</sup>
Protection class housing/ball bearing <sup>1)</sup>	E, F: IP 65/64; D, H: IP 64/64 <sup>2)</sup>
Operating temperature	RI 58-D: -10 ... +70 °C; RI 58TD: -25 ... +100 °C
Storage temperature	-25 ... +85 °C
Vibration performance (IEC 68-2-6)	10 g = 100 m/s <sup>2</sup> (10 ... 2000 Hz)
Shock resistance (IEC 68-2-27)	100 g = 1000 m/s <sup>2</sup> (6 ms)
Type of connection	cable radial, connector radial
Housing	aluminium
Weight	E, F: 170 g approx.; D, H: 190 g approx.

<sup>1)</sup> no standing water allowed at the shaft entrance or at the ball bearing  
<sup>2)</sup> when mounted

### Electrical data

General design	as per DIN VDE 0160, protection class III, contamination level 2, overvoltage class II					
Screening	connected to housing					
Noise emission	as per EN 50081-2 (edition 1993)					
Noise immunity	as per EN 50082-2 (edition 1995)					
Power consumption	40 mA (5 V DC), 30 mA (24 V DC), 60 mA (10 V DC)					
Supply voltage U <sub>B</sub>	5 V DC (SELV) $\pm$ 10%		10 ... 30 V DC (SELV)			
Output circuit <sup>1)</sup>	PP	PP	RS422	PP	PP compl.	RS422
Code letter	K	D	R, T	K	I	R
Output load [mA]	$\pm$ 10	$\pm$ 30	$\pm$ 30	$\pm$ 30	$\pm$ 30	$\pm$ 30
Output level [V]	High	$\geq$ 2.5	$\geq$ 2.5	$\geq$ 2.5	U <sub>B</sub> -3	U <sub>B</sub> -3
	Low	$\leq$ 0.5	$\leq$ 0.5	$\leq$ 0.5	$\leq$ 2	$\leq$ 0.5
Pulse rise time [ns]	250	100	100	2000	2000	100
Max. pulse frequency [kHz]	300	300	300	200	200	300
Pole protection of U <sub>B</sub>	yes	no	no	yes	yes	yes
Short circuit proof	yes	1 channel	1 channel	yes	yes	yes
Pulse duty factor	1 : 1					
Pulse width error	$\pm$ 25° electrical					
Phase shift	90° (Channel A to B is at least 0.45 $\mu$ s at 300 kHz)					
Pulse shape	rectangular					
Alarm output	Open Collector, NPN (5 mA, 24 V max. with U <sub>B</sub> =5VDC; 5 mA, 32 V max. with U <sub>B</sub> =10...30 VDC)					

<sup>1)</sup> PP = Push-pull; PP compl. = Push-pull complementary; RS422 = Line driver

### Pinout of flange box, CONIN 12 poles

Pin	RS 422 (T)	RS 422 (R)	Push-pull (K, D)	Push-pull complementary(I)
1	Channel $\bar{B}$	Channel $\bar{B}$	N.C.	Channel $\bar{B}$
2	Sense V <sub>CC</sub>	Sense V <sub>CC</sub>	N.C.	Sense V <sub>CC</sub>
3	Channel N	Channel N	Channel N	Channel N
4	Channel $\bar{N}$	Channel $\bar{N}$	N.C.	Channel $\bar{N}$
5	Channel A	Channel A	Channel A	Channel A
6	Channel $\bar{A}$	Channel $\bar{A}$	N.C.	Channel $\bar{A}$
7	N.C.	Alarm	Alarm	Alarm
8	Channel B	Channel B	Channel B	Channel B
9	N.C.*	N.C.*	N.C.*	N.C.*
10	GND	GND	GND	GND
11	Sense GND	N.C.	N.C.	N.C.
12	5 V DC	5/10 ... 30 VDC	5/10 ... 30 VDC	10 ... 30 VDC

\* Screen for cable with CONIN-plug

# Incremental Hollow Shaft Encoder RI 58-D, RI 58TD

Page 2/2

## Mechanical installation

### General information

### Safety instructions

- All installation work must be carried out according to applicable safety instructions!
- During installation work all appliances worked on must be disconnected from electric current!  
Ensure that these appliances cannot be powered up during the installation work!
- In order to compensate for axial or radial angular offset of the actuating shaft, flange and case of the shaft encoder must remain movable!

The shaft encoder case must not rotate:

Fix the flange by means of

- a stator coupling (e.g. spring steel plate) (Accessories: Ord. code 1 531 162)
- or a cylindrical pin. A torque spring (at the encoder flange) in conjunction with a cylindrical pin (at the actuating device) provides for the transmission of torque between encoder and actuating device.

### Prerequisites for installation

#### at the actuating shaft (only in version E):

The actuating shaft must be provided with a threaded bore M4x10:  
This bore accepts the fastening screw of the shaft encoder.

#### at the actuator case (for mounting with cylindrical pin):

A cylindrical pin must be installed in the actuator housing (pin diameter versions E and H: 4x16; versions D and F: 4x20; always DIN 6325).

This pin is required as a torque support (refer also to safety instructions)  
Please observe the following dimensioned drawings.

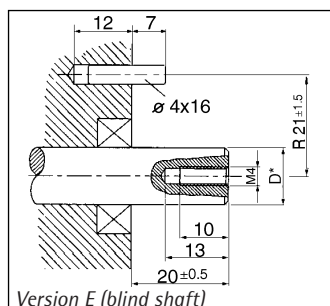
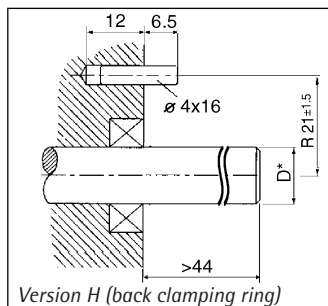
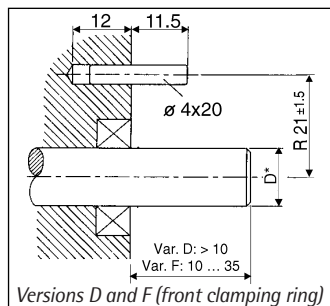

\* D = 10/12/14 mm (versions D + H)  
\* D = 10/12/14/15 mm (versions E + F)

### Assembly drawings

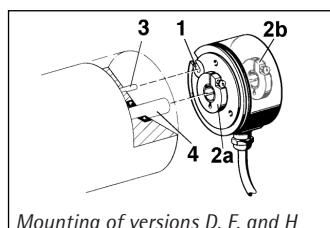

Mounting of versions D, F, and H

#### Legend for versions D, F, and H

- 1 Torque spring
- 2a Clamping ring with hexagon-socket screw, front (D+F)
- 2b Clamping ring with hexagon-socket screw, back (H)
- 3 Cylindrical pin
- 4 Actuating shaft

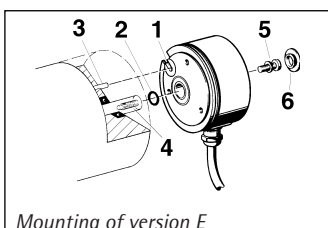

Mounting of version E

#### Legend for version E

- 1 Torque spring
- 2 O-ring
- 3 Cylindrical pin
- 4 Actuating shaft with threaded bore
- 5 M4-screw with spring washer
- 6 Cap

### Checking the clamping device (D, F, and H versions)

The clamping device of versions D, F, and H contains a clamping ring with a hexagon-socket screw.

**Versions D and F:** Clamping ring and torque spring are located on the front side of the shaft encoder. This side will later on point to the actuator.  
With version H, the clamping ring is located in the back, the torque spring is in front.

The front side will later on point to the actuator.

Check first whether the clamping ring is open:

- Hold the encoder in such a position that you can see the clamping ring from the side: The hexagon-socket screw is inserted into the side of the clamping ring.
- Check whether the clamping device of the hollow shaft is released by inserting the actuating shaft into the hollow shaft.  
The shaft must slide into the hollow shaft smoothly!  
**Do not use force and do not try to drive the shaft into the hollow with hammer blows!**  
**This would damage the shaft encoder!**
- If the shaft cannot be inserted: check the shaft diameter and/or release the clamping device.

### Releasing the clamping device (D, F, and H versions)

- Open the clamping ring:  
Use a hex key (size 2); turn the screw to the left (counter-clockwise).

### Mounting the encoder at the actuating shaft

#### For clamping shaft/clamping device versions (D, F, and H):

- For mounting with stator coupling:  
Fasten the spring steel plate to the encoders flange.
- Slide the encoder onto the actuating shaft.
- For mounting with cylindrical pin:  
Align the encoder in such a position that the torque spring and the cylindrical pin oppose each other. Engage the cylindrical pin in the torque spring.
- For mounting with stator coupling:  
Align the encoder in such a position that the bores of the spring steel plate and of the actuator housing oppose each other.
- Close the clamping ring:  
Use a hex key (size 2); turn the screw to the right (clockwise).  
**Tightening torque of the clamping-ring screw: 90 ... 100 Ncm!**
- For mounting with stator coupling:  
Screw together the spring steel plate and the actuator housing.

#### For blind shaft version (E):

- For mounting with stator coupling:  
Fasten the spring steel plate to the encoders flange.
- Put the O-ring\* into the hollow shaft and slide the encoder onto the actuating shaft.
- For mounting with cylindrical pin:  
Align the encoder in such a position that the torque spring and the cylindrical pin oppose each other. Engage the cylindrical pin in the torque spring.
- For mounting with stator coupling:  
Align the encoder in such a position that the bores of the spring steel plate and of the actuator housing oppose each other.
- Put the spring washer\* on the Phillips screw (M4x12)\*.  
Hold the spring washer to the screw head.
- Push the screw with the spring washer through the case opening and the shaft bore of the encoder into the threaded bore at the end of the actuating shaft.
- Secure the encoder on the actuating shaft:  
Use a Phillips screwdriver;  
Turn the screw to the right (clockwise) and tighten it moderately.
- Push the cap\* into the case opening.
- For mounting with stator coupling:  
Screw together the spring steel plate and the actuator housing.

\* supplied with the encoder

**The encoder is now ready for connection.**

**Ensure that no external forces act on the shaft encoder during installation and operation!**